

PT 10 V3 ASSEMBLY MANNUAL

Product List

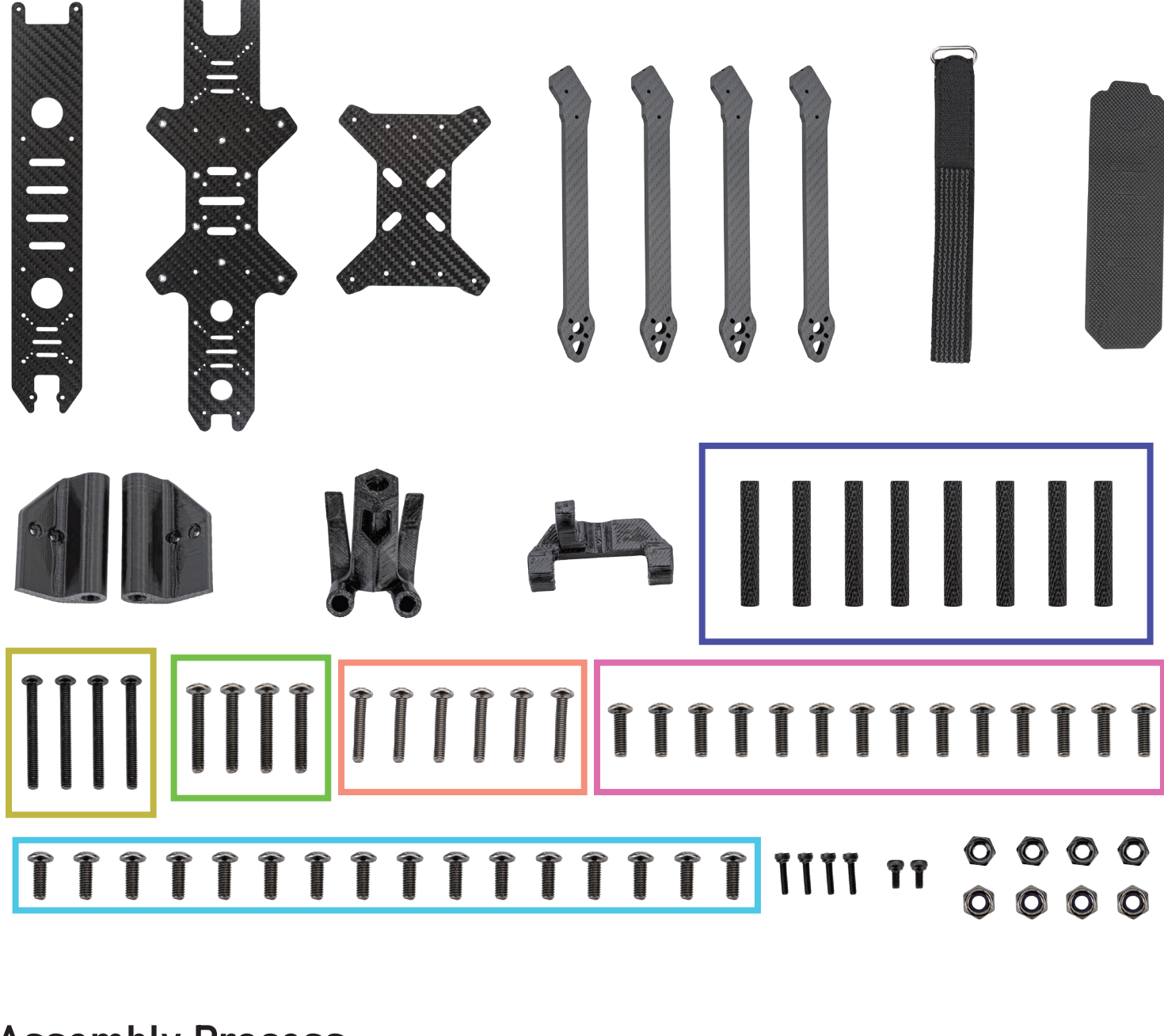

Assembly Process

First, place the middle plate with the side containing the press-fit nuts facing down. Align the holes and position the four arms as indicated in the diagram.

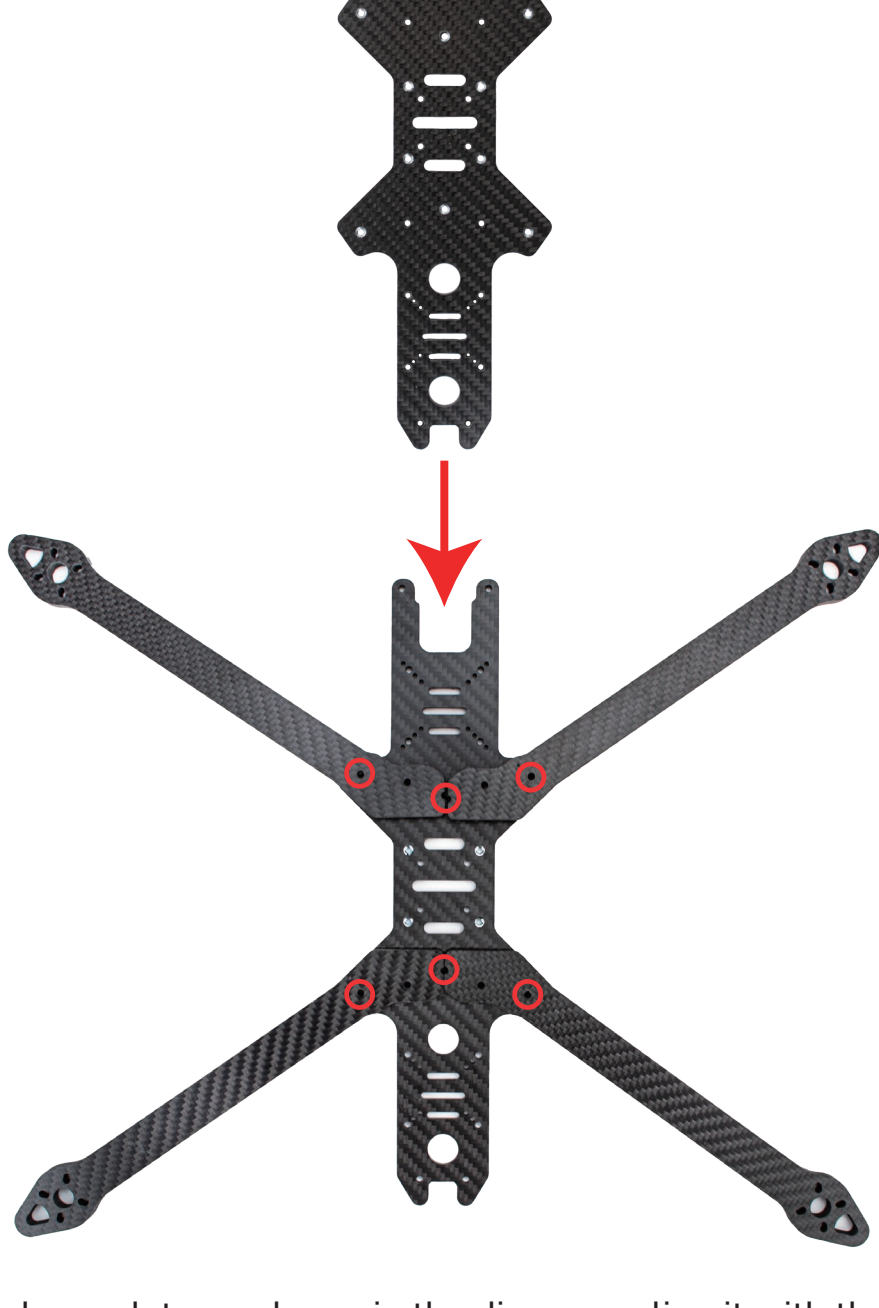

Then, position the base plate as shown in the diagram, align it with the holes, and secure it with six screws.

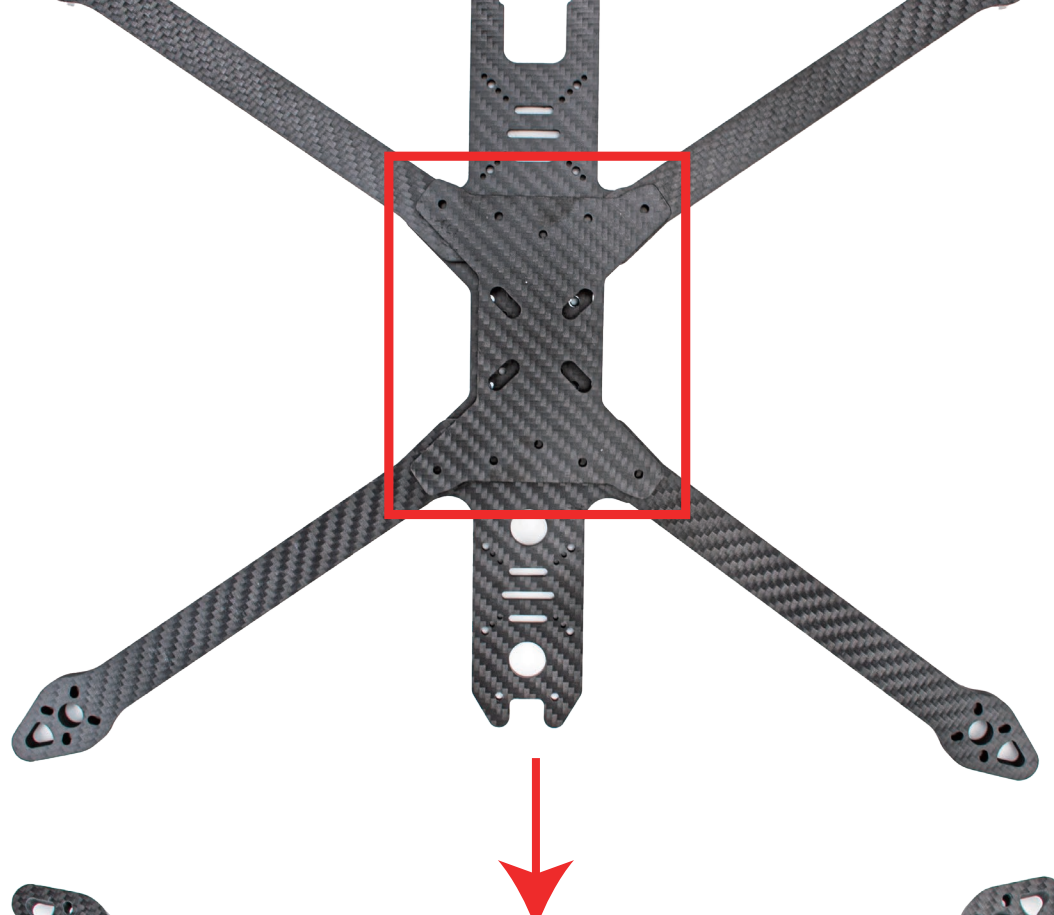

Position the side with the press-fit nuts facing up, insert screws into the eight marked holes, and then attach the aluminum standoffs.

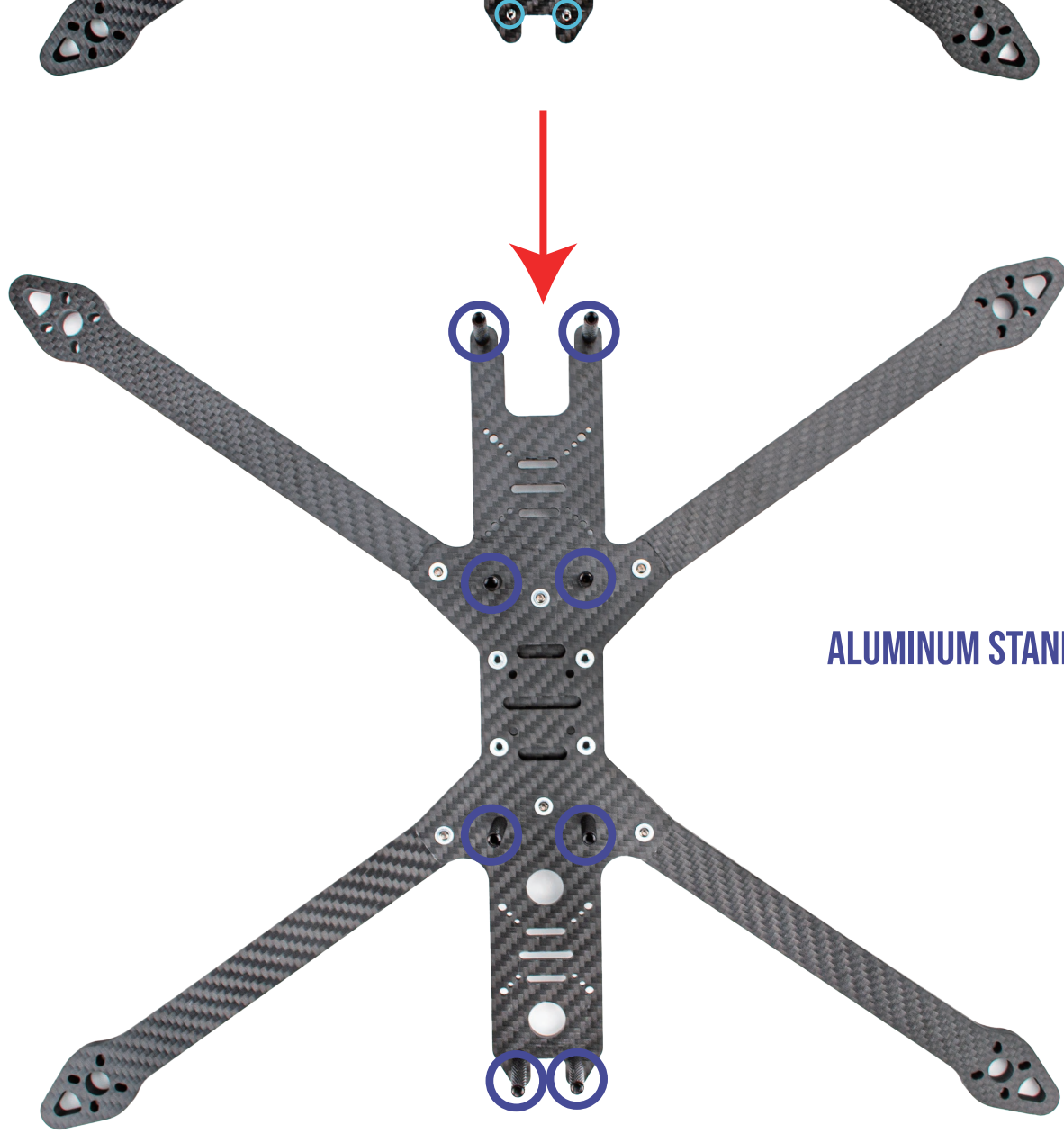
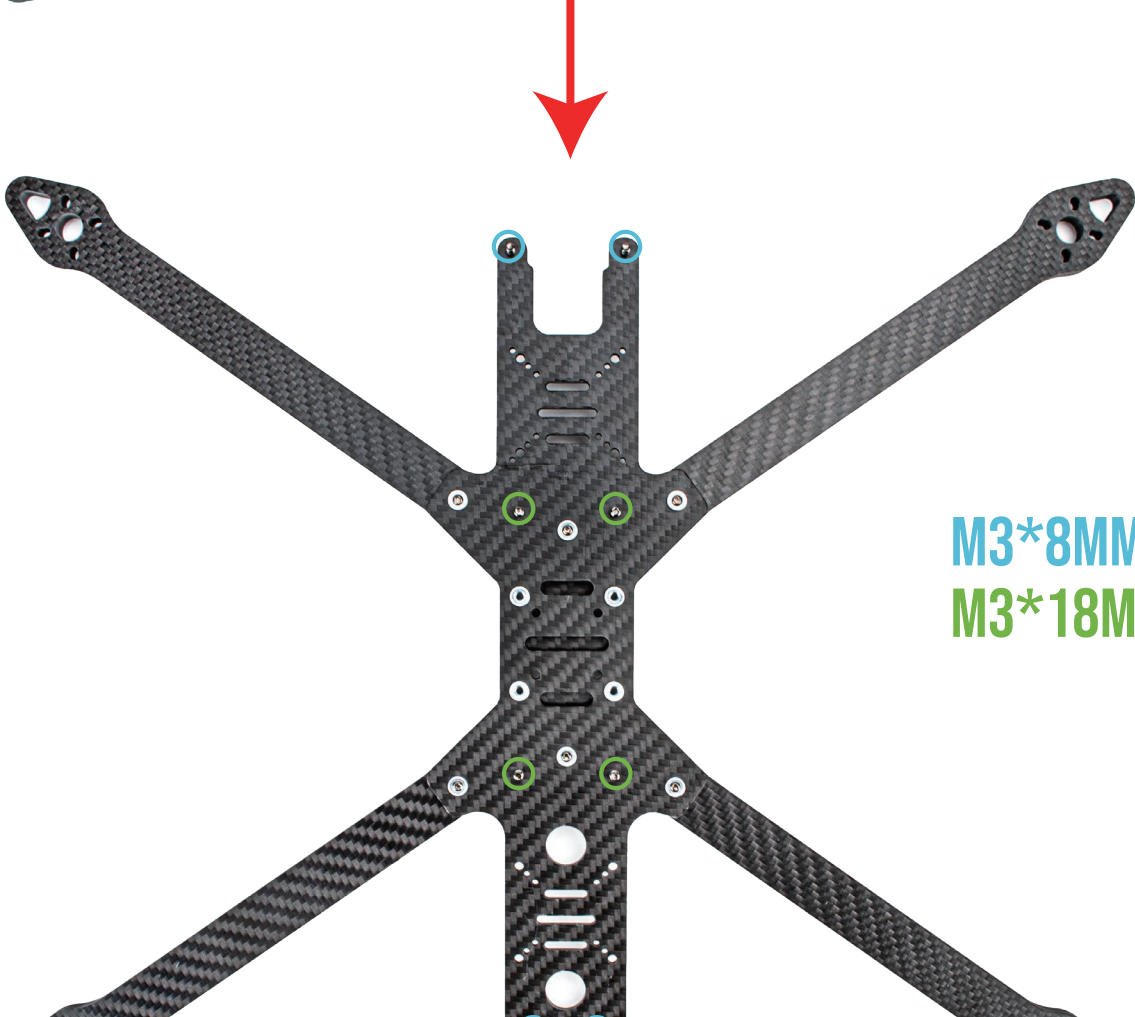
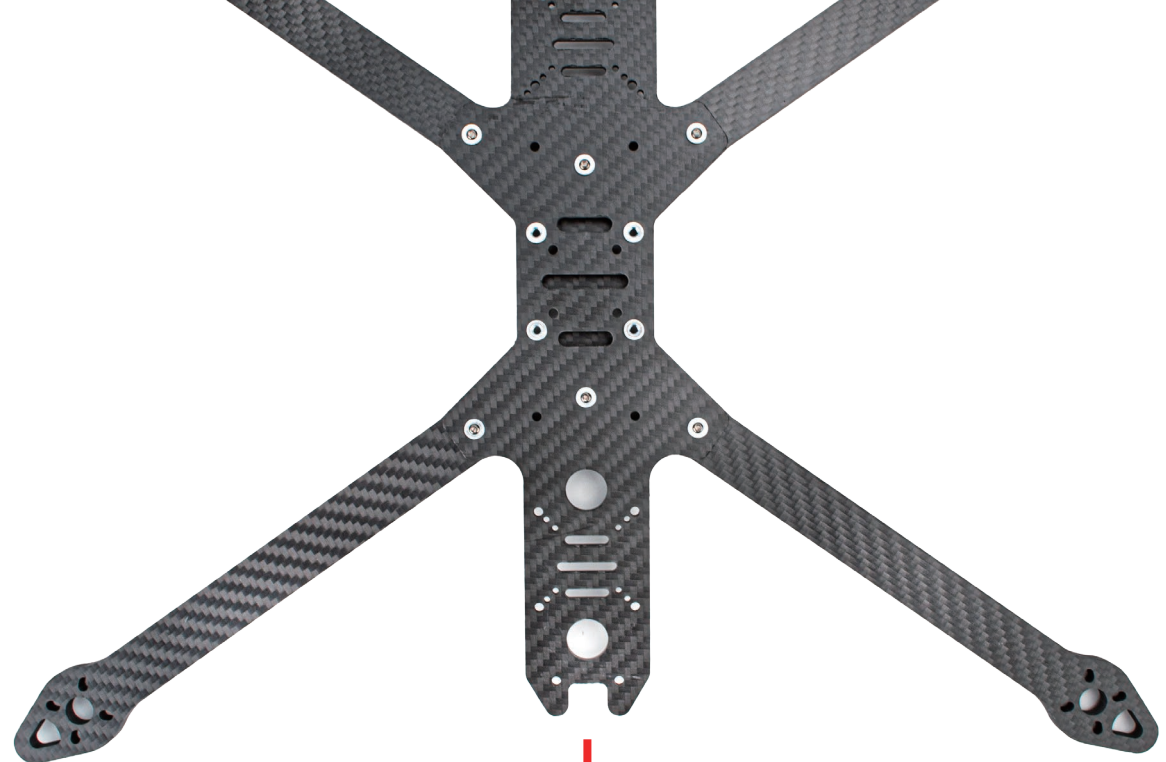

Attach the 3D-printed camera mount to the front and the VTX antenna mount to the rear. Then, secure the four flight controller screws in the center, place the top plate, align therear receiver antenna mount with the holes, and finally fasten the remaining eight screws.

